

SA5000, SA5015, SA7000, SA7015 PARTS LIST

| Ref. Part | Number | Ref. Part | Number | Ref. Part | Number |
|--------------------------------|---------|-----------------------------------|---------|--|---------|
| A Retaining Ring (2) | 205191 | AL Reel Assy. (SA5000/SA7000) | 304349 | BJ Switch Assy. (SA5015 & SA7015) | 304325 |
| B Bushing | 204012 | AN Cover Plug | 204713 | BK Wiring Harness Complete (SA5015 & SA7015) | 5241518 |
| C Drive Shaft Assy. | 304813 | AP Cover | 404804 | BL Relay Assy. (SA5015 & SA7015) | 304971 |
| D Bushing | 204009 | AP Cover (SA5015 & SA7015) | 404990 | F Aux. Handle Assy. (SA5000) | 304412 |
| E 56T Gear | 204703 | AU Cable & Hook-3/16x20' (SA5000) | 5240692 | G Base Spacer | 404557 |
| F Handle Assy. (SA5000) | 304412 | AU Cable & Hook-3/16x50' (SA7000) | 5240445 | H Base | 404922 |
| G Base Spacer | 404557 | AV Screw, 1/4-20x7/8 (2) | 205242 | K Brake Spring Replacement Kit | 5703186 |
| H Base | 404922 | AW Top Decal (Not Shown) | 206421 | L Locknut, 7/16-20 | 205192 |
| K Brake Spring Replacement Kit | 5703186 | AY D-L Decal (Not Shown) | 204729 | M Nut, 7/16-20 Locknut | 205192 |
| L Locknut, 7/16-20 | 205192 | AZ Pulley Block & Hook (Complete) | 5240270 | N Clutch Stud | 404535 |
| M Nut, 7/16-20 Locknut | 205192 | | | P Washer (7) | 204360 |
| N Clutch Stud | 404535 | | | Q Locknut | 205015 |
| P Washer (7) | 204360 | | | U 120T Gear Assy. | 304414 |
| Q Locknut | 205015 | | | Y Front Plate Spacer (3) | 404562 |
| U 120T Gear Assy. | 304414 | | | Z Front Plate | 404553 |
| Y Front Plate Spacer (3) | 404562 | | | AA Screw, 1/4-20x5/8 (3) | 205238 |
| Z Front Plate | 404553 | | | AB Locknut, 10-32 (2) | 205193 |
| AA Screw, 1/4-20x5/8 (3) | 205238 | | | AC Brake Disc Assy. | 304407 |
| AB Locknut, 10-32 (2) | 205193 | | | AD Motor Pinion | 404522 |
| AC Brake Disc Assy. | 304407 | | | AE 'E' Ring | 205135 |
| AD Motor Pinion | 404522 | | | AF Reel Shaft | 404559 |
| AE 'E' Ring | 205135 | | | AG Retaining Ring | 204468 |
| AF Reel Shaft | 404559 | | | AH Screw, 1/4-20x3/8 (2) | 205337 |
| AG Retaining Ring | 204468 | | | AJ Cable Clamp Kit | 304617 |
| AH Screw, 1/4-20x3/8 (2) | 205337 | | | AK Screw, 1/4-20x3/4 (2) | 205338 |
| AJ Cable Clamp Kit | 304617 | | | | |
| AK Screw, 1/4-20x3/4 (2) | 205338 | | | | |

MOTOR PARTS
 BA Motor Assy. (SA5000/SA7000) 304349
 BA Motor Assy. (SA5015 & SA7015) 304973
 BB Switch Assy. (SA5000/SA7000) 5240494 (Includes Items BC, BE & BF)
 BC Cap Screw, 1/4-20x3/8 205018
 BE Hex Nut 206225
 BF Breaker Assy. 304025
 BG Pocket Plate Repair Kit 5703129
 BH Replacement Switch Kit 5240411

To order replacement parts contact:
Dutton-Lainson Company
 www.dlco.com
 Tel: 800-569-6577
 Fax: 402-460-4612
 e-mail: DLsales@dutton-lainson.com

In Europe Contact:
Aqua-Marine International Ltd.
 8 Flanders Park
 Hedge End, Southampton
 Hants, England SO30 2FZ
 Tel: +44 (0) 1489-776050
 Fax: +44 (0) 1489-776055
 e-mail: sales@aqua-marineint.co.uk

SA9000, SA9005, SA9015, SA12000, SA12015 PARTS LIST

| Ref. Part | Number | Ref. Part | Number | Ref. Part | Number |
|---------------------------------------|---------|-----------------------------------|---------|---|---------|
| A Bearing Housing Assy. | 304314 | AD Level Wind | 204709 | CA Motor Assy (SA9000/SA12000) | 304349 |
| B Primary Drive Shaft Assy. | 304304 | AE Nut, 10-32 Locknut (2) | 205193 | CA Motor Assy (SA9015 & SA12015) | 304973 |
| C Retaining Ring (2) | 205191 | AF Brake Disc Assy. | 304422 | CB Switch Assy. (SA9000/SA12000) | 5240494 |
| D Bushing (2) | 204012 | AH 12T Pinion Gear | 404522 | (Includes Items CC, CF & CG) | |
| E 56T Gear | 204703 | AJ "E" Ring | 205135 | CC Screw - 1/4x20x3/8 | 205018 |
| F Aux. Handle Assy. (SA5015 & SA7015) | 304412 | AK Base Spacer | 404510 | CD Relay Assy. (SA9015 & SA12015) | 304972 |
| G Drive Shaft Bearing Housing Assy. | 304313 | AL Reel Shaft | 404514 | CE Switch Assy. (SA9015 & SA12015) | 304325 |
| H Interm. Drive Shaft Assy. | 304814 | AM Retaining Ring | 204468 | CF Nut - 1/4-20 | 206225 |
| I "E" Ring | 205116 | AN Screw, 1/4x20x1/2" (4) | 205189 | CG Circuit Breaker Assy. | 304025 |
| L Base | 404921 | AP Washer (2) | 205109 | CH Wiring Harness Complete (SA9015 & SA12015) | 5241518 |
| M Base (SA9015/SA12015) | 404980 | AR Reel Assy. | 304815 | CJ Pigtail - (SA9015 & SA12015) | 304917 |
| N Nut, 7/16-20 Locknut | 205192 | AT Rope Clamp Kit | 5243506 | CK Strain Relief (SA9015 & SA12015) | 205037 |
| O Clutch Stud | 404535 | AV Cover (DC) | 404632 | CL Pocket Plate Replacement Kit | 5703129 |
| P Washer (8) | 204360 | AV Cover (SA9015 & SA12015) | 404991 | CM Replacement Switch Kit | 5240411 |
| Q Gear Assy. | 304319 | AW Cover Plug | 204713 | CN Connector | 206055 |
| R Nut | 205015 | AZ Cable & Hook (7/32x25') (Opt.) | 5240478 | CP Screw, 6-32x7/8 (2) | 204959 |
| S Brake Spring Replacement Kit | 5703160 | BA Pulley Block & Hook (Complete) | 5240452 | CQ Screw, 1/4-20x3/8 (2) | 205337 |
| T Screw, 1/4-20x1" (2) | 205190 | BE Top Decal (DC) (Not Shown) | 5240270 | CR Remote Switch (Complete) (SA9005) | 5240668 |
| U Spacer (3) | 404513 | BH Screw 1/4-20x7/8 (3) | 205242 | | |
| V Front Plate | 404511 | | | | |
| W Level Wind Pin | 404516 | | | | |

To order replacement parts contact:
Dutton-Lainson Company
 www.dlco.com
 Tel: 800-569-6577
 Fax: 402-460-4612
 e-mail: DLsales@dutton-lainson.com

In Europe Contact:
Aqua-Marine International Ltd.
 8 Flanders Park
 Hedge End, Southampton
 Hants, England SO30 2FZ
 Tel: +44 (0) 1489-776050
 Fax: +44 (0) 1489-776055
 e-mail: sales@aqua-marineint.co.uk

DUTTON-LAINSON COMPANY
 Hastings, NE 68902 U.S.A • Tel 402-462-4141 • Fax 402-460-4612
 E-mail dlsales@dutton-lainson.com • Web Site www.dutton-lainson.com

StrongArm 12 Volt DC ELECTRIC WINCHES

OWNER'S MANUAL

MODELS SA5000, SA5015, SA7000, SA7015, SA9000, SA9005, SA9015, SA12000 & SA12015



WARNING: READ INSTRUCTIONS CAREFULLY BEFORE ATTEMPTING TO INSTALL, OPERATE OR SERVICE THE STRONGARM ELECTRIC WINCH. FAILURE TO COMPLY WITH INSTRUCTIONS COULD RESULT IN SERIOUS OR FATAL INJURY. RETAIN INSTRUCTIONS FOR FUTURE REFERENCE.

WINCH RATINGS

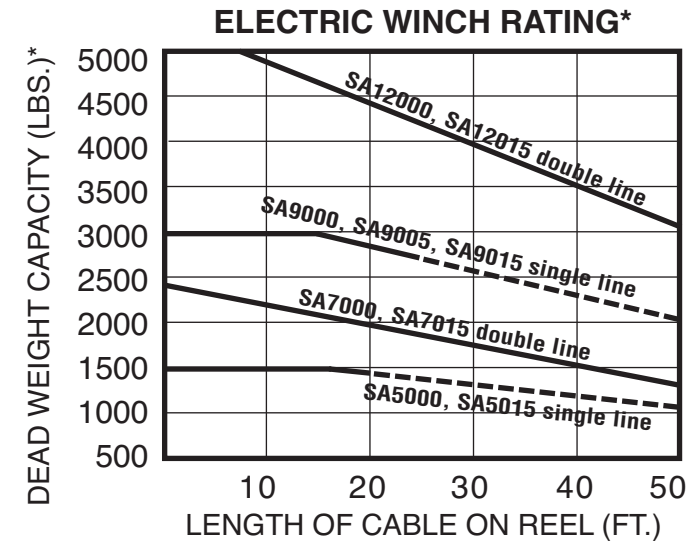

DOUBLE LINE OPERATION
 Models SA7000, SA7015, SA12000 and SA12015 are factory equipped with a pulley block and hook and 50' of cable for double line operation. This increases the pulling capacity of the winch as shown, however, care must be taken to allow adequate motor cooling. Note that with double line, a pull of 25' requires reeling in 50' of cable. For intermittent use only. Ratings at left are based on 10' pull. For longer pulls motor cooling periods must be allowed.

CAUTION: CONTINUOUS RUNNING IN EXCESS OF 4 MINUTES WILL DAMAGE WINCH MOTOR.

GUIDE TO ROLLING LOAD CAPACITY**
 Maximum weight in pounds and kilograms rolling load.

| MODEL | PERCENT INCLINE | | | | | | LOAD CAPACITY* |
|------------------------|-----------------------|-----------------------|----------------------|----------------------|---------------------|---------------------|---------------------|
| | 5% (3°) | 10% (6°) | 20% (11°) | 30% (17°) | 50% (26°) | 70% (35°) | |
| SA5000, SA5015 | 10,000 lbs. 4,536 kg | 7,500 lbs. 3,402 kg | 5,100 lbs. 2,313 kg | 3,900 lbs. 1,769 kg | 2,700 lbs. 1,225 kg | 2,200 lbs. 998 kg | 1,500 lbs. 680 kg |
| SA7000, SA7015 | 14,600 lbs. 6,623 kg | 11,000 lbs. 4,990 kg | 7,400 lbs. 3,357 kg | 5,700 lbs. 2,586 kg | 4,000 lbs. 1,814 kg | 3,300 lbs. 1,497 kg | 2,200 lbs. 998 kg |
| SA9000, SA9005, SA9015 | 20,000 lbs. 9,072 kg | 15,000 lbs. 6,804 kg | 10,200 lbs. 4,627 kg | 7,700 lbs. 3,493 kg | 5,500 lbs. 2,495 kg | 4,500 lbs. 2,041 kg | 3,000 lbs. 1,361 kg |
| SA12000, SA12015 | 30,000 lbs. 13,608 kg | 22,600 lbs. 10,251 kg | 15,200 lbs. 6,895 kg | 11,600 lbs. 5,262 kg | 8,300 lbs. 3,765 kg | 6,800 lbs. 3,084 kg | 4,500 lbs. 2,041 kg |

APPROXIMATE LOAD SPEED (FT./MIN.)

| MODEL | NO LOAD | | FULL LOAD | |
|--------------------------------|-----------|------------|-----------|------------|
| | Full Reel | Empty Reel | Full Reel | Empty Reel |
| SA5000, SA5015, SA7000, SA7015 | 33 | 12 | 8 | 4 |
| SA9000, SA9005, SA9015 | 11 | 5 | 4 | 2.5 |
| SA12000, SA12015 | 9 | 2.5 | 2 | 1.5 |

(* Load capacity (dead weight) is a measure of actual maximum force to which the winch system may be subjected.
 (** All capacities shown are with 15' of cable on the reel and 10% rolling friction factor. For full reel of cable adjust capacities according to graph above. Note 5% incline is one-half foot rise in ten feet.)

WARNING: NOT TO BE USED AS A HOIST FOR LIFTING, SUPPORTING OR TRANSPORTING PEOPLE OR LOADS OVER AREAS WHERE PEOPLE COULD BE PRESENT!

IMPORTANT SAFETY INFORMATION

⚠ WARNING: FAILURE TO READ AND FOLLOW INSTRUCTIONS BELOW COULD RESULT IN SERIOUS OR FATAL INJURY.

⚠ WARNING: NOT TO BE USED AS A HOIST FOR LIFTING, SUPPORTING, OR TRANSPORTING PEOPLE OR LOADS OVER AREAS WHERE PEOPLE COULD BE PRESENT.

⚠ This winch is not designed for movement of human beings. Do not use for scaffolding, elevators, or any other application in which persons could be positioned on or under the load at any time. Do not use as an overhead hoist.

⚠ This electric winch should be respected as power equipment. High forces are created when using a winch, creating potential safety hazards. Never allow children or anyone who is not familiar with the operation of the winch to use it.

⚠ Never exceed rated winch capacity. Dangerously high forces can be created if the load being moved is too large or is allowed to get in a bind, etc. Note that installing longer than normal cable results in increased load on winch. If overloaded, this winch has power enough to break the cable.

⚠ Inspect the winch cable often and replace at the first sign of damage. Never exceed the winch capacity. When cable breaks under tension, it tends to whip toward the winch area. It is recommended that a blanket or rug be placed over the cable during winching operations to minimize this whipping action in case of cable breakage.

⚠ Never apply load to winch with cable fully extended. Keep at least three turns of cable on the reel.

⚠ Keep the winching area free of all unnecessary personnel. Never stand between load and winch.

⚠ The 12 volt D.C. winch operates from a low voltage D.C. source of power (e.g., a car or truck battery). DO NOT connect winch to 120V A.C. power.

⚠ When winching operation has been completed, do not depend on the winch to support the load. Always secure the load properly. Use tie down straps or chains.

⚠ The auxiliary handle is provided for emergency use only. Never use the auxiliary handle as an assist to the motor when the motor is running. Always remove the auxiliary handle when it is not in use. Do not operate the winch motor with the handle installed.

⚠ Keep hands and fingers clear of the drum and cable area of the winch when operating. Do not attempt to guide the cable by hand as it rewinds on the drum.

⚠ The winch must be securely attached to a structural member or frame that is capable of sustaining loads in excess of the winch capacity. When attaching the winch to a vehicle, make sure the mounting pad area is rigidly supported by the vehicle frame. Always block the wheels to prevent vehicle from rolling when pulling a load with the winch. Do not use vehicle pulling power to increase the pulling capacity of your winch.

MODELS SA5000, SA7000, SA9000 & SA12000

With the wires at the bottom, push the switch/plug into the pocket in the winch housing. The switch should push easily to the bottom of the pocket and excess force should not be required for installation or removal. Rotate the switch in the direction indicated on the winch decal to power the load in or out. Be sure the wires are free to rotate with the switch so that it will return to its center "Off" position when released.

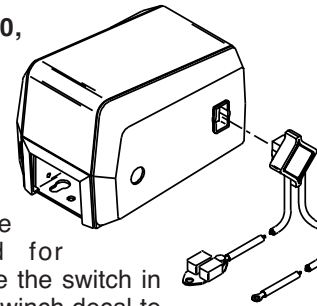

MODELS SA5015, SA7015, SA9015 & SA12015

Attach the power supply plug into the connector located at the back of the winch. This plug pushes and snaps into place easily and will fit in only one direction. Connect the remote switch cord to the short cord coming from the back of the winch. The winch can be operated by depressing the "In" or "Out" side of the switch, which will return to off when released.

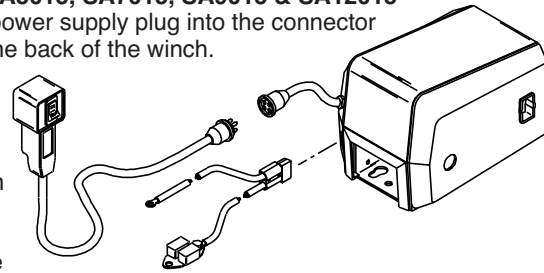

OPERATING INSTRUCTIONS

All models can be powered in or out. Allowing the switch to return to the off position will automatically stop the winch and hold the load.

NOTE: It is normal for smoke to be produced during the initial power down use.

Be sure the battery is fully charged and in top condition to avoid power loss. If using a vehicle battery, leave the engine running on fast idle as a precaution in case the battery is not in top condition.

When the winching operation is complete, secure the load properly with tie down straps or chains. Do not depend on the winch to support the load. Also, remove the power supply plug from the winch to avoid accidental operation.

⚠ WARNING: EVEN THOUGH THE WINCH IS EQUIPPED WITH CIRCUIT BREAKER OVERLOAD PROTECTION, PARTICULAR CARE SHOULD BE TAKEN NOT TO CREATE AN OVERLOAD. PAY ATTENTION TO THE SOUND OF THE WINCH AND THE LOAD BEING PULLED. MAKE CERTAIN THAT THE CABLE TENSION DOES NOT RISE SUDDENLY BECAUSE OF A BIND IN THE LOAD.

⚠ CAUTION: The electric motor is designed for intermittent service only. Extended use without cooling off periods will cause overheating resulting in motor damage. Maximum continuous run time is four minutes.

⚠ WARNING: NEVER ALLOW CHILDREN, OR ANYONE WHO IS NOT FAMILIAR WITH THE OPERATION OF THE WINCH, TO USE IT.

AUXILIARY HANDLE

1. An emergency crank handle is provided for use in the event of a power failure. Remove the electrical power from the winch.
 2. Remove the plastic plug from the side of the winch housing and insert the handle so that it completely engages with the drive shaft. The handle can be cranked in either direction.
- ⚠ WARNING: NEVER OPERATE THE WINCH ELECTRICALLY WITH THE EMERGENCY HANDLE IN POSITION.**
3. Always remove the handle from the winch after use and replace the plastic plug.

WINCH MAINTENANCE

For long life and trouble-free operation your winch should periodically be inspected for any required maintenance. This should be done at least once annually and more frequently in adverse conditions such as salt water areas or areas of extreme dust and dirt.

1. Carefully inspect the winch cable for any kinks, frays or abnormal stiffness and replace at the first sign of this kind of damage. Periodic lubrication with a light oil will improve the life of the cable. In order to replace the winch cable, it is necessary to remove the four cover mounting bolts. Be sure that the power is disconnected from the housing and lift the housing off of the winch by gently stretching it open near the lower front corner. Rotate the winch reel so that you have access to the rope clamp. Remove the old cable and replace it with a new cable of the same size. Be sure that the cable passes under both sides of the rope clamp and that the clamp is tightened securely.

NOTE: CABLE IS WOUND OVER THE TOP OF THE DRUM ON MODELS SA5000, SA5015, SA7000 AND SA7015 AND UNDER THE DRUM ON MODELS SA9000, SA9005, SA9015, SA12000 AND SA12015. SEE ATTACHMENT METHOD BELOW.

CABLE ATTACHMENT METHODS

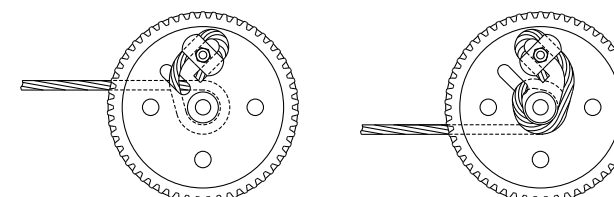

MODELS SA5000, SA5015, SA7000 & SA7015

MODELS SA9000, SA9005, SA9015, SA12000 & SA12015

2. With the cover removed as described above, inspect the entire gear train and all drive shafts for any significant wear or loose bearings fits. Grease all of the gears on the inside of the winch base and apply a drop of oil on all of the bearings in the base. Also, place a drop of oil on the roller clutch. Do not over lubricate these areas and do not use grease in the roller clutch. The brake pads and brake disc must be kept clean and oil free.
3. Check the operation of the roller clutch. Carefully rotate the brake disc and observe the motor shaft. When the disc is turned clockwise the motor shaft should turn with it. When the disc is turned counterclockwise the motor shaft should not turn. Also, check all nuts, bolts, retaining rings, etc., to be sure that they are tight and secure.
4. On Models SA5000, SA7000, SA9000 and SA12000, check the switch contact studs in the winch housing to be sure that they are free from any corrosion or excessive electrical pitting. Make sure that the housing shunt spring is properly in place and making contact with both contact pins.
5. If a pulley block and hook is used, check assembly to be sure that the pulley rotates freely on the bronze pulley spacer. Occasional greasing of these two items is recommended.

TROUBLESHOOTING CHART

| SYMPTOM | POSSIBLE CAUSE(S) | CORRECTIVE ACTION |
|---|--|---|
| Safety hook spreads. | 1. Point loading of hook. 2. Load exceeds rated capacity of unit. | 1. Replace hook. 2. Lighten load, reduce % of incline or reduce load friction. |
| Cable breaks. | 1. Cable damage due to miswrap. 2. Overloading. | 1. Keep tension on cable at all times. 2. Reduce load. |
| Cable miswrap and/or crushing. | Loose cable being wound onto drum. | Keep tension on cable at all times. |
| Load creeps when power is OFF. | 1. Roller clutch, not engaging. 2. Overloading. | 1. Replace. 2. Reduce load. |
| Damaged level wind spring Models SA9005, SA9000, SA9015, SA12000 & SA12015 | Loose cable. | Keep tension on cable at all times. |
| Winch motor runs hot. | In operation too long. | Let motor cool for at least 20 minutes. (See Winch Rating Section). |
| Winch motor fails to run. | Electrical. | Check the following: power supply, wiring, control switch, male/female connections and motor. |
| Smokes | Normal on initial power down use. | None. |

WIRING DIAGRAM

SA5000, SA7000, SA9000, SA9005* and SA12000

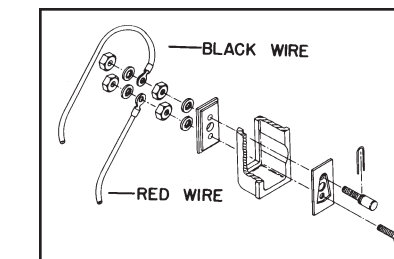

*NOTE: See additional switch wiring diagram on back of Assembly/Operating instructions packed in poly bag with switch components.

WIRING DIAGRAM

SA5015, SA7015, SA9015 and SA12015

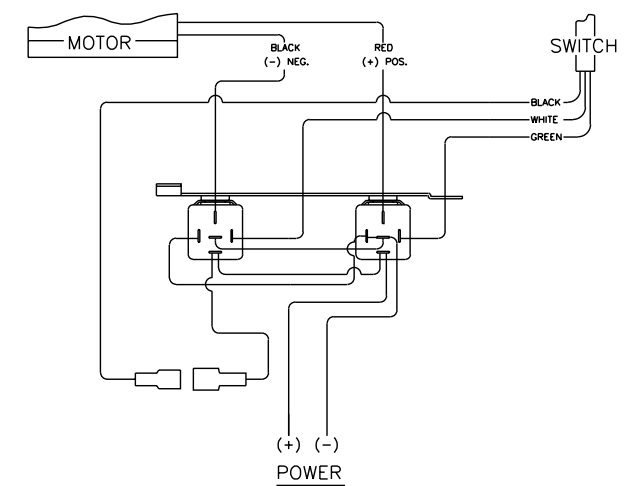

MOUNTING INSTRUCTIONS

1. Be sure that the mounting surface is of sufficient strength to support a load well in excess of the rated winch capacity. Fasten the winch to the mounting surface with three 1/2" bolts, nuts, washers, and lockwashers. (See base hole pattern.) Be sure that the winch is positioned so that the cable does not rub the front opening of the winch. Your winch is equipped with key hole slots in the base for use with quick-mounting shoulder studs if desirable. If you wish to use quick-mount studs, they should be mounted securely into the mounting surface. After positioning the winch on the studs, a 3/8" bolt should be placed in one of the other holes available to keep the winch securely in position. For double line use, install an eye-hook on the mounting surface close to the base of the winch for fastening the stationary cable hook. Be sure the eye-hook is of sufficient strength to withstand loads in excess of the single line rating of the winch.

WIRING & SWITCH INSTALLATION

MODEL SA9005

Refer to the complete assembly and operating instructions packed in the poly bag with the switch.

MODELS SA5000, SA5015, SA7000, SA7015, SA9000, SA9015, SA12000 and SA12015.

Attach the circuit breaker assembly on the end of the positive (+) wire to the positive battery terminal. Attach negative (-) wire (ground) to the negative battery terminal or a convenient ground location. Make certain that connections are clean and tight. If the wiring is being permanently installed in a vehicle, the wires should be secured so that they cannot come into contact with hot or moving parts.

Continued on next page

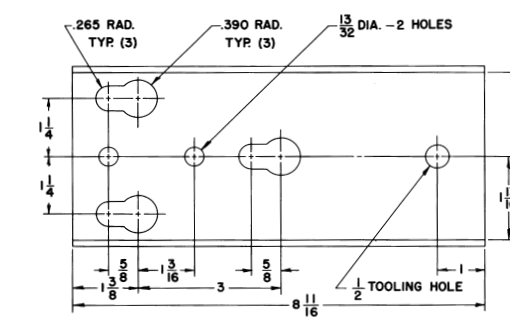

BASE HOLE PATTERN

SA5000, SA5015, SA7000 and SA7015

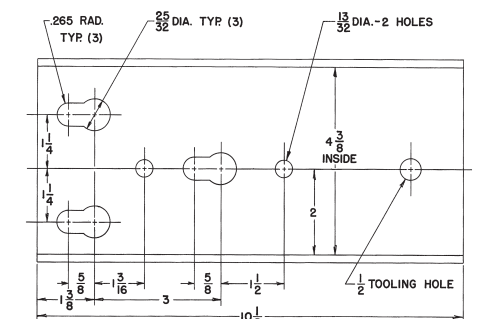

BASE HOLE PATTERN

SA9000, SA9005, SA9015, SA12000 and SA12015