



6800 SERIES SWIVEL JACK



WARNING READ INSTRUCTIONS CAREFULLY BEFORE ATTEMPTING TO INSTALL, OPERATE OR SERVICE THIS JACK. FAILURE TO COMPLY WITH INSTRUCTIONS COULD RESULT IN SERIOUS INJURY. RETAIN THESE INSTRUCTIONS FOR FUTURE REFERENCE.

ASSEMBLY

Bolted Swivel Mount Assemble jack as shown in the parts drawing making sure that the protrusion in the center of the clover washer enters the center hole in the swivel plate. Printing on the swivel bracket washer should not be visible after assembly. Tighten nuts evenly.

Snap Ring Swivel Mount Assemble jack as shown in the parts drawing and install retaining ring with snap ring pliers. Make certain that snap ring is securely seated in groove.

MOUNTING

Bolt-on Place jack on trailer tongue in a location that avoids interference with the boat, trailer and tow vehicle during all conditions of use. Make sure the jack cannot contact the tow vehicle when making tight turns. Tighten all bolts evenly.

Weld-on Weld on jack brackets need to be installed by a competent welder. Determine location per instruction above.

After bracket is painted, assemble jack according to the parts drawing and assembly instructions above. Note that bolts (YY) are self-threading and require considerable installation force.

OPERATION

Check for full engagement of the swivel handle into the swivel plate before every use of the jack.

WARNING Use of a swivel type jack without the swivel handle completely engaged could result in the trailer tongue suddenly dropping and could cause personal injury.

When jack reaches either end of its travel do not force handle or damage to the jack will result. When moving trailer by hand, crank jack to lowest position. Do not use the jack as a convenient hand hold. Avoid rolling jack over rough or soft surfaces. Before towing the trailer, pivot the jack to horizontal position and be certain swivel handle is engaged.

CAUTION Loads in excess of rating shown on jack label will cause accelerated wear and possible failure. This jack is not for highway use. Never tow trailer with load applied to jack.

MAINTENANCE

Minimal maintenance is required to keep your tongue jack looking new and in good working order. Protect the finish by keeping it clean and periodically applying a coating of wax. Lubrication is needed if the jack ever feels rough or produces a grinding noise when cranked. With weight off the jack, remove the plastic end cap. Remove pin (1) holding handle in place. Carefully remove the bevel gear (2) on top of screw. Remove dowel pin (3) located under bevel gear. Carefully remove inner tube assembly. Do not attempt to remove screw from inner tube. Lubricate screw by working grease into entire thread. Reassemble and grease bevel gears.

CE UK EC Declaration of Conformity –
CA CA Dutton-Lainson Company, Hastings, NE 68902-0729 U.S.A. manufactures and declares that the winch identified above fulfills all relevant provisions of the Directive 2006/42/EC, and Supply of Machinery (Safety) Regulations 2008. The technical file may be obtained from the persons listed below.

Hastings, NE USA
January 2, 2024
Jeff Dolbin
Director of Engineering
Dutton-Lainson Company

Jack Singleton
Eurowarehouse BV
De Amstel 11
8253PC Dronten
The Netherlands



A Dependable Company Since 1886

DUTTON-LAINSON COMPANY
Hastings, NE 68902 U.S.A. • Tel 402-462-4141 • Fax 402-460-4612
www.dutton-lainson.com • E-mail: dlsales@dutton-lainson.com

MADE IN
U.S.A.

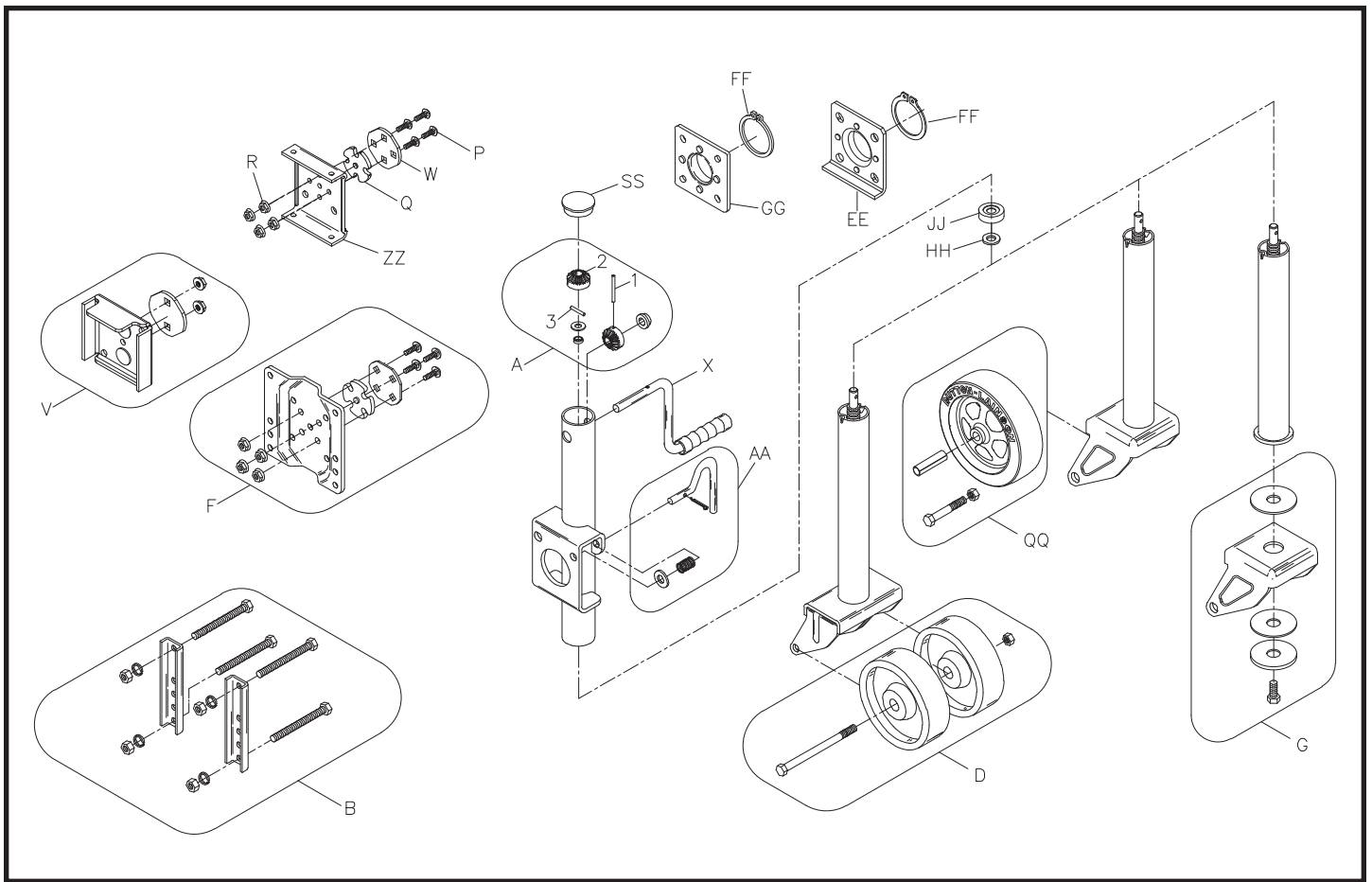

6800 Series Swivel Jack Parts List

Ref.	Description	Part No.	Ref.	Description	Part No.
A	6813A Miter Gear Kit	5224399	AA	Swivel Handle 3/8" Dia. Kit	5224498
B	6804 Clamp & Bolt Kit	5224431	AA	Swivel Handle 1/2" Dia. Kit	5224548
D	6802 Dual Poly Wheel	5224415	EE	Snap Ring Weld on Bracket, 1/2" Handle	5226717
F	6808 Swivel Plate Kit for 3/8" Handle	5224449	FF	Retaining Ring	203916
F	6808 Swivel Plate Kit for 1/2" Handle	5224258	GG	Snap Ring Weld on Bracket, 3/8" Handle	403411
G	8" Wheel Bracket Ass'y	5226386	HH	Flat Washer	207120
P	Carriage Bolt 3/8"-16 x 1" (4)	205389	JJ	Thrust Bearing	207121
Q	Clover Leaf Washer	403283	QQ	8 Inch Wheel (6807)	5224100
R	Flanged Lock Nut 3/8" - 16 (4)	205285	SS	AG Jack Cap (6602)	5226287
V	Weld on Bracket Assy (6610)	5227533	ZZ	6684 4-1/2" Channel Mount Plate	403594
W	Swivel Bracket Washer, (4 bolt)	403282	ZZ	6685 5-1/2" Channel Mount Plate	403595
X	6811A Jack Handle w/Pin	5224480	ZZ	6686 6-1/2" Channel Mount Plate	403596

To order these accessories or replacement parts contact your D-L dealer or

Pour commander ces accessoires ou des pièces de rechange, se mettre en contact avec le concessionnaire D-L ou

Para pedir estos accesorios o repuestos, comuníquese con el concesionario de D-L o con

Dutton-Lainson Company
 www.dlco.com
 Tel: 800-569-6577
 Fax: 402-460-4612
 e-mail: DLsales@dutton-lainson.com